

Cree Edge™ Series

LED High Output Area/Flood Luminaire featuring Cree TrueWhite® Technology

Product Description

The Cree Edge™ High Output Area/Flood luminaire is designed to deliver high lumen packages with precise optical control. The unit features a slim, low profile design that minimizes wind load and a rugged die cast aluminum adjustable arm that mounts to a horizontal or vertical 2" (51mm) IP, 2.375-2.50" (60-64mm) O.D. steel tenon. Tenon length must be a minimum of 3.75" (95mm). The direct mount bracket accessory allows for further mounting flexibility. Available with Cree TrueWhite® Technology, the Cree Edge™ High Output helps to beautifully render true colors and deliver value beyond energy savings.

Applications: Auto dealerships, parking lots, campuses, facade lighting, high-mast and general site lighting applications

Performance Summary

- Utilizes BetaLED® Technology
- Utilizes Cree TrueWhite® Technology on 5000K Luminaires
- Patented NanoOptic® Product Technology
- Made in the U.S.A. of U.S. and imported parts
- CRI: Minimum 70 CRI (4000K & 5700K); 90 CRI (5000K)
- CCT: 4000K (+/- 300K), 5000K (+/- 300K), 5700K (+/- 500K) standard
- Limited Warranty*:** 10 years on luminaire/10 years on Colorfast DeltaGuard® finish

Accessories

Field-Installed		
Bird Spikes XA-BRDSPKXAK12 - 120 LED XA-BRDSPKXAK24 - 240 LED	Backlight Control Shields XA-30BLS-4 - Four-pack for 120 LED - Unpainted stainless steel XA-30BLS-8 - Eight-pack for 240 LED - Unpainted stainless steel	Direct Mount Bracket EHO-UNV** - Mounts to minimum 4" (102mm) round or square; aluminum or steel pole or can be surface-mounted directly to a vertical or horizontal surface - See Direct Mount Configuration table on page 15 - Poles must be field drilled for direct mount

** Must specify color



HV Mount (shown in horizontal position)



120 LED

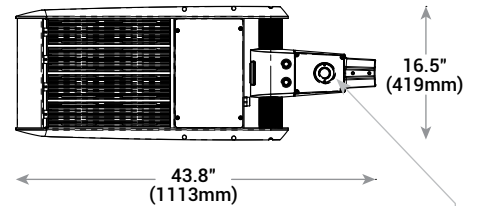

NEMA® Photocell Receptacle location (ordered as an option)

240 LED

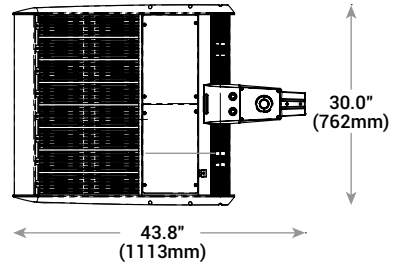

Ordering Information

Example: ARE EHO 2M HV 12 E UL SV 700

Product	Optic	Mounting	LED Count (x10)	Series	Voltage	Color Options	Drive Current	Options
ARE EHO	1S Type I Short 2M Type II Medium 2MB Type II Medium w/BLS 2MP Type II Medium w/Partial BLS 2S Type II Short 2SB Type II Short w/BLS 2SP Type II Short w/Partial BLS 3M Type III Medium 3MB Type III Medium w/BLS 3MP Type III Medium w/Partial BLS 4M Type IV Medium 4MB Type IV Medium w/BLS 4MP Type IV Medium w/Partial BLS 5M Type V Medium 5S Type V Short AF Automotive Frontline	HV Horizontal/Vertical Tenon	12 24	E	UL Universal 120-277V UH Universal 347-480V	SV Silver BK Black BZ Bronze PB Platinum Bronze WH White	700 700mA 1000 1000mA	40K 4000K Color Temperature - Minimum 70 CRI - Color temperature per luminaire 50K 5000K Color Temperature - Minimum 90 CRI - Utilizes Cree TrueWhite® Technology - Color temperature per luminaire DIM 0-10V Dimming - Control by others - Refer to Dimming spec sheet for details - Can't exceed specified drive current F Fuse - When code dictates fusing, use time delay fuse - Refer to ML spec sheet for availability with ML options - No available with UH voltage ML Multi-Level - Refer to ML spec sheet for details - Intended for downlight applications at 0° tilt R NEMA® Photocell Receptacle - Intended for downlight applications with maximum 45° tilt - Consult factory for vertical tenon application - Photocell by others - Refer to ML spec sheet for availability with ML options
FLD EHO	15 15' Flood 25 25' Flood 40 40' Flood 70 70' Flood SN Sign N6 NEMA 6							

* See www.cree.com/lighting/products/warranty for warranty terms



Rev. Date: V3 12/09/2014



US: www.cree.com/lighting

T (800) 236-6800 F (262) 504-5415

Canada: www.cree.com/canada

T (800) 473-1234 F (800) 890-7507

Cree Edge™ High Output Area/Flood Luminaire

Product Specifications

CREE TRUEWHITE® TECHNOLOGY

A revolutionary way to generate high-quality white light, Cree TrueWhite® Technology is a patented approach that delivers an exclusive combination of 90+ CRI, beautiful light characteristics, and lifelong color consistency, all while maintaining high luminous efficacy – a true no compromise solution.

CONSTRUCTION & MATERIALS

- Slim, low profile, minimizing wind load
- Luminaire sides are rugged die cast aluminum with integral, weathertight LED driver compartments and high performance heat sinks
- Adjustable arm that mounts to a horizontal or vertical 2" (51mm) IP, 2.375-2.50" (60-64mm) O.D. steel tenon. Tenon length must be a minimum of 3.75" (95mm)
- Surface-mount directly to a vertical or horizontal surface with direct mount bracket
- Extruded aluminum adjustable mounting shaft
- Luminaire is adjustable from horizontal 90° towards pole and 120° away from pole
- Exclusive Colorfast DeltaGuard® finish features an E-Coat epoxy primer with an ultra-durable powder topcoat, providing excellent resistance to corrosion, ultra-violet degradation and abrasion. Silver, bronze, black, white, and platinum bronze are available
- **Weight:** 120 LED: 45.3 lbs. (20.6kg); 240 LED: 80.5 lbs. (36.6kg)

ELECTRICAL SYSTEM

- **Input Voltage:** 120-277V or 347-480V, 50/60Hz, Class 1 drivers
- **Power Factor:** > 0.9 at full load
- **Total Harmonic Distortion:** < 20% at full load
- Integral 10kV surge suppression protection standard
- To address inrush current, slow blow fuse or type C/D breaker should be used
- **Maximum Source Current:** 120 LED: 0.40mA; 240 LED: 0.80mA

REGULATORY & VOLUNTARY QUALIFICATIONS

- cULus Listed
- Suitable for wet locations
- Consult factory for CE Certified products
- 10kV surge suppression protection tested in accordance with IEEE/ANSI C62.41.2
- Meets FCC Part 15 standards for conducted and radiated emissions
- Certified to ANSI C136.31-2001, 3G bridge and overpass vibration standards
- DLC qualified. Exceptions apply when ordered with full or partial backlight control, 5000K CCT with 1000mA drive current, or 5000K CCT with 700mA drive current and 2M, 3M or 70 optics. Please refer to <http://www.designlights.org/QPL> for most current information
- Luminaire and finish endurance tested to withstand 5,000 hours of elevated ambient salt fog conditions as defined in ASTM Standard B 117
- Meets Buy American requirements within ARRA
- Dark Sky Friendly, IDA Approved. Please refer to <http://www.darksky.org/> for most current information
- RoHS compliant. Consult factory for additional details

Electrical Data*							
LED Count (x10)	System Watts 120-480V	Total Current					
		120V	208V	240V	277V	347V	480V
700mA							
12	267	2.24	1.29	1.12	0.99	0.80	0.58
24	533	4.49	2.57	2.24	1.97	1.62	1.16
1000mA							
12	421	3.61	2.06	1.80	1.61	1.25	0.90
24	831	7.16	4.04	3.54	3.14	2.50	1.81

* Electrical data at 25°C (77°F). Actual wattage may differ by +/- 7% when operating between 120-480V +/- 10%

Recommended Cree® Edge High Output Series Lumen Maintenance Factors (LMF) ¹					
Ambient	Initial LMF	25K hr Projected ² LMF	50K hr Projected ² LMF	75K hr Projected ³ LMF	100K hr Calculated ³ LMF
5°C (41°F)	1.04	0.99	0.97	0.95	0.93
10°C (50°F)	1.03	0.98	0.96	0.94	0.92
15°C (59°F)	1.02	0.97	0.95	0.93	0.91
20°C (68°F)	1.01	0.96	0.94	0.92	0.90
25°C (77°F)	1.00	0.95	0.93	0.91	0.89

¹ Lumen maintenance values at 25°C are calculated per TM-21 based on LM-80 data and in-situ luminaire testing

² In accordance with IESNA TM-21-11, Projected Values represent interpolated value based on time durations that are within six times (6X) the IESNA LM-80-08 total test duration (in hours) for the device under testing ((DUT) i.e. the packaged LED chip)

³ In accordance with IESNA TM-21-11, Calculated Values represent time durations that exceed six times (6X) the IESNA LM-80-08 total test duration (in hours) for the device under testing ((DUT) i.e. the packaged LED chip)

HV Mount (shown in vertical position)

120 LED

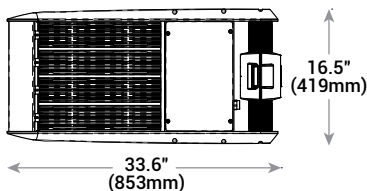

240 LED

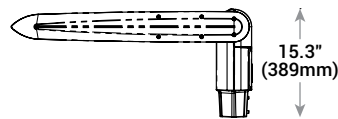
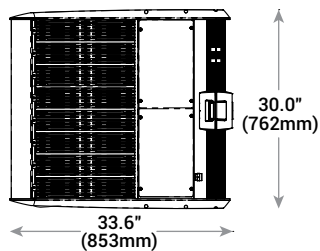

Direct Mount Bracket (accessory sold separately)

120 LED

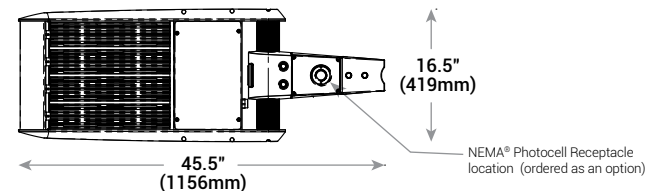

240 LED

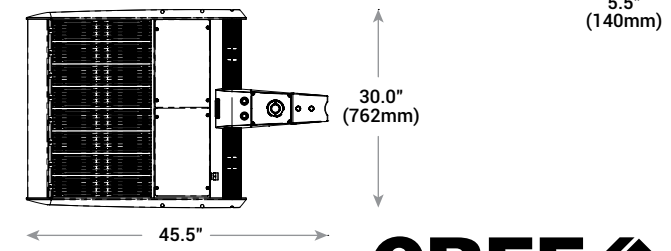

Photometry

All published luminaire photometric testing performed to IESNA LM-79-08 standards by a NVLAP certified laboratory. To obtain an IES file specific to your project consult: <http://www.cree.com/lighting>.

1S

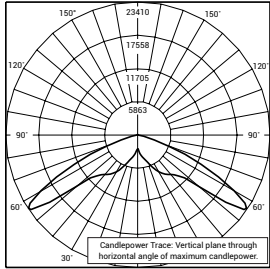

ITL Test Report #: 78640
ARE EHO 1S ** 12 E UL 1000 40K
Initial Delivered Lumens: 37,812

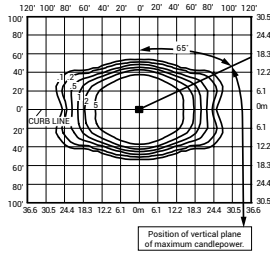

ARE EHO 1S ** 24 E UL 1000 40K
Mounting Height: 25' (7.6m) A.F.G.
Initial Delivered Lumens: 72,507
Initial FC at grade

Type I Short Distribution

LED Count (x10)	4000K		5000K		5700K	
	Initial Delivered Lumens*	BUG Ratings** Per TM-15-11	Initial Delivered Lumens*	BUG Ratings** Per TM-15-11	Initial Delivered Lumens*	BUG Ratings** Per TM-15-11
700mA						
12	26,980	B5 U1 G3	21,376	B4 U1 G3	28,018	B5 U1 G4
24	53,994	B5 U1 G4	42,780	B5 U1 G4	56,071	B5 U1 G5
1000mA						
12	36,230	B5 U1 G4	28,706	B5 U1 G4	37,624	B5 U1 G4
24	72,507	B5 U1 G5	57,448	B5 U1 G5	75,295	B5 U1 G5

* Initial delivered lumens at 25°C (77°F). Actual production yield may vary between -4 and +10% of initial delivered lumens
** For more information on the IES BUG (Backlight-Uplight-Glare) Rating visit: www.iesna.org/PDF/Erratas/TM-15-11BugRatingsAddendum.pdf. Valid with no tilt

2M

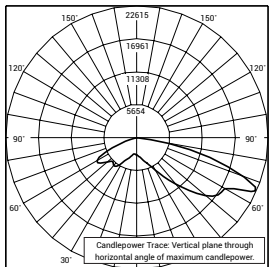

ITL Test Report #: 78643
ARE EHO 2M ** 12 E UL 1000 40K
Initial Delivered Lumens: 32,284

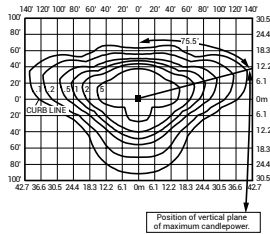

ARE EHO 2M ** 24 E UL 1000 40K
Mounting Height: 25' (7.6m) A.F.G.
Initial Delivered Lumens: 61,352
Initial FC at grade

Type II Medium Distribution

LED Count (x10)	4000K		5000K		5700K	
	Initial Delivered Lumens*	BUG Ratings** Per TM-15-11	Initial Delivered Lumens*	BUG Ratings** Per TM-15-11	Initial Delivered Lumens*	BUG Ratings** Per TM-15-11
700mA						
12	22,829	B3 U1 G3	18,088	B3 U1 G3	23,707	B3 U1 G3
24	45,687	B5 U1 G4	36,199	B4 U1 G4	47,445	B5 U1 G4
1000mA						
12	30,656	B4 U1 G4	24,289	B3 U1 G3	31,835	B4 U1 G4
24	61,352	B5 U1 G5	48,609	B5 U1 G4	63,711	B5 U1 G5

* Initial delivered lumens at 25°C (77°F). Actual production yield may vary between -4 and +10% of initial delivered lumens
** For more information on the IES BUG (Backlight-Uplight-Glare) Rating visit: www.iesna.org/PDF/Erratas/TM-15-11BugRatingsAddendum.pdf. Valid with no tilt

Cree Edge™ High Output Area/Flood Luminaire

Photometry

All published luminaire photometric testing performed to IESNA LM-79-08 standards by a NVLAP certified laboratory. To obtain an IES file specific to your project consult: <http://www.cree.com/lighting>.

2MB

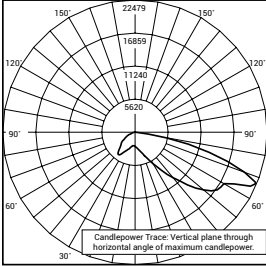

ITL Test Report #: 78683
 ARE EHO 2MB ** 12 E UL 1000 40K
 Initial Delivered Lumens: 24,579

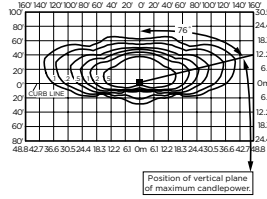

ARE EHO 2MB ** 24 E UL 1000 40K
 Mounting Height: 25' (7.6m) A.F.G.
 Initial Delivered Lumens: 46,213
 Initial FC at grade

Type II Medium w/BLS Distribution						
LED Count (x10)	4000K		5000K		5700K	
	Initial Delivered Lumens*	BUG Ratings** Per TM-15-11	Initial Delivered Lumens*	BUG Ratings** Per TM-15-11	Initial Delivered Lumens*	BUG Ratings** Per TM-15-11
700mA						
12	17,196	B2 U1 G2	13,625	B2 U1 G2	17,857	B2 U1 G2
24	34,414	B3 U1 G4	27,266	B3 U1 G3	35,738	B3 U1 G4
1000mA						
12	23,092	B2 U1 G3	18,296	B2 U1 G2	23,980	B2 U1 G3
24	46,213	B3 U1 G4	36,615	B3 U1 G4	47,990	B3 U1 G5

* Initial delivered lumens at 25°C (77°F). Actual production yield may vary between -4 and +10% of initial delivered lumens
 ** For more information on the IES BUG (Backlight-Uplight-Glare) Rating visit: www.iesna.org/PDF/Erratas/TM-15-11BugRatingsAddendum.pdf. Valid with no tilt

2MP

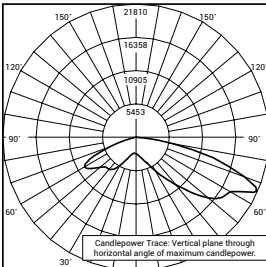

ITL Test Report #: 78688
 ARE EHO 2MP ** 12 E UL 1000 40K
 Initial Delivered Lumens: 28,203

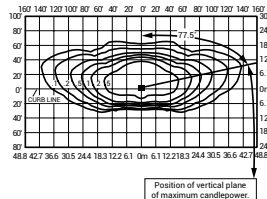

ARE EHO 2MP ** 24 E UL 1000 40K
 Mounting Height: 25' (7.6m) A.F.G.
 Initial Delivered Lumens: 54,181
 Initial FC at grade

Type II Medium w/Partial BLS Distribution						
LED Count (x10)	4000K		5000K		5700K	
	Initial Delivered Lumens*	BUG Ratings** Per TM-15-11	Initial Delivered Lumens*	BUG Ratings** Per TM-15-11	Initial Delivered Lumens*	BUG Ratings** Per TM-15-11
700mA						
12	20,161	B3 U1 G3	15,974	B2 U1 G2	20,936	B3 U1 G3
24	40,347	B4 U1 G4	31,968	B3 U1 G3	41,899	B4 U1 G4
1000mA						
12	27,073	B3 U1 G3	21,450	B3 U1 G3	28,114	B3 U1 G3
24	54,181	B4 U1 G4	42,928	B4 U1 G4	56,265	B4 U1 G5

* Initial delivered lumens at 25°C (77°F). Actual production yield may vary between -4 and +10% of initial delivered lumens
 ** For more information on the IES BUG (Backlight-Uplight-Glare) Rating visit: www.iesna.org/PDF/Erratas/TM-15-11BugRatingsAddendum.pdf. Valid with no tilt



Cree Edge™ High Output Area/Flood Luminaire

Photometry

All published luminaire photometric testing performed to IESNA LM-79-08 standards by a NVLAP certified laboratory. To obtain an IES file specific to your project consult: <http://www.cree.com/lighting>.

2S

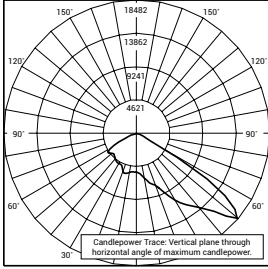

ITL Test Report #: 78639
ARE EHO 2S ** 12 E UL 1000 40K
Initial Delivered Lumens: 34,478

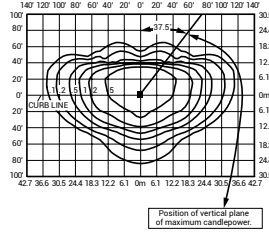

ARE EHO 2S ** 24 E UL 1000 40K
Mounting Height: 25' (7.6m) A.F.G.
Initial Delivered Lumens: 65,336
Initial FC at grade

Type II Short Distribution

LED Count (x10)	4000K		5000K		5700K	
	Initial Delivered Lumens*	BUG Ratings** Per TM-15-11	Initial Delivered Lumens*	BUG Ratings** Per TM-15-11	Initial Delivered Lumens*	BUG Ratings** Per TM-15-11
700mA						
12	24,312	B3 U1 G3	19,262	B3 U1 G3	25,247	B3 U1 G3
24	48,654	B5 U1 G4	38,549	B4 U1 G4	50,525	B5 U1 G4
1000mA						
12	32,647	B4 U1 G4	25,867	B3 U1 G3	33,903	B4 U1 G4
24	65,336	B5 U1 G5	51,766	B5 U1 G4	67,849	B5 U1 G5

* Initial delivered lumens at 25°C (77°F). Actual production yield may vary between -4 and +10% of initial delivered lumens
** For more information on the IES BUG (Backlight-Up/ight-Glare) Rating visit: www.iesna.org/PDF/Erratas/TM-15-11BugRatingsAddendum.pdf. Valid with no tilt

2SB

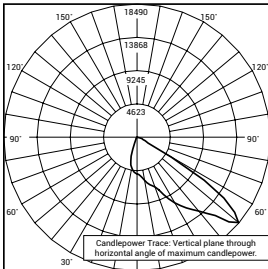

ITL Test Report #: 78684
ARE EHO 2SB ** 12 E UL 1000 40K
Initial Delivered Lumens: 26,431

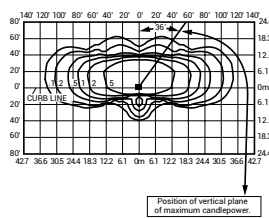

ARE EHO 2SB ** 24 E UL 1000 40K
Mounting Height: 25' (7.6m) A.F.G.
Initial Delivered Lumens: 50,197
Initial FC at grade

Type II Short w/BLS Distribution

LED Count (x10)	4000K		5000K		5700K	
	Initial Delivered Lumens*	BUG Ratings** Per TM-15-11	Initial Delivered Lumens*	BUG Ratings** Per TM-15-11	Initial Delivered Lumens*	BUG Ratings** Per TM-15-11
700mA						
12	18,678	B3 U1 G2	14,799	B2 U1 G2	19,397	B3 U1 G2
24	37,381	B3 U1 G3	29,617	B3 U1 G3	38,818	B3 U1 G3
1000mA						
12	25,083	B3 U1 G3	19,873	B3 U1 G2	26,047	B3 U1 G3
24	50,197	B4 U1 G4	39,771	B3 U1 G3	52,128	B4 U1 G4

* Initial delivered lumens at 25°C (77°F). Actual production yield may vary between -4 and +10% of initial delivered lumens
** For more information on the IES BUG (Backlight-Up/ight-Glare) Rating visit: www.iesna.org/PDF/Erratas/TM-15-11BugRatingsAddendum.pdf. Valid with no tilt

Cree Edge™ High Output Area/Flood Luminaire

Photometry

All published luminaire photometric testing performed to IESNA LM-79-08 standards by a NVLAP certified laboratory. To obtain an IES file specific to your project consult: <http://www.cree.com/lighting>.

2SP

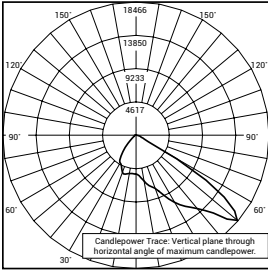

ITL Test Report #: 78686
 ARE EHO 2SP ** 24 E UL 1000 40K
 Initial Delivered Lumens: 30,296

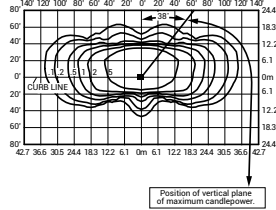

ARE EHO 2SP ** 24 E UL 1000 40K
 Mounting Height: 25' (7.6m) A.F.G.
 Initial Delivered Lumens: 58,165
 Initial FC at grade

Type II Short w/Partial BLS Distribution						
LED Count (x10)	4000K		5000K		5700K	
	Initial Delivered Lumens*	BUG Ratings** Per TM-15-11	Initial Delivered Lumens*	BUG Ratings** Per TM-15-11	Initial Delivered Lumens*	BUG Ratings** Per TM-15-11
700mA						
12	21,643	B3 U1 G3	17,148	B3 U1 G3	22,476	B3 U1 G3
24	43,314	B4 U1 G4	34,318	B4 U1 G3	44,980	B4 U1 G4
1000mA						
12	29,064	B3 U1 G3	23,028	B3 U1 G3	30,182	B3 U1 G3
24	58,165	B4 U1 G4	46,084	B4 U1 G4	60,402	B4 U1 G4

* Initial delivered lumens at 25°C (77°F). Actual production yield may vary between -4 and +10% of initial delivered lumens
 ** For more information on the IES BUG (Backlight-Uplight-Glare) Rating visit: www.iesna.org/PDF/Erratas/TM-15-11BugRatingsAddendum.pdf. Valid with no tilt

3M

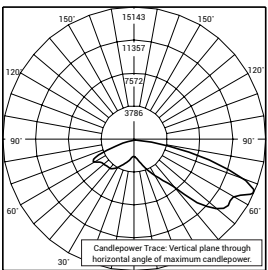

ITL Test Report #: 78638
 ARE EHO 3M ** 12 E UL 1000 40K
 Initial Delivered Lumens: 30,916

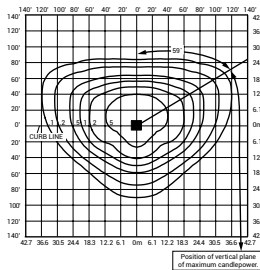

ARE EHO 3M ** 24 E UL 1000 40K
 Mounting Height: 25' (7.6m) A.F.G.
 Initial Delivered Lumens: 58,165
 Initial FC at grade

Type III Medium Distribution						
LED Count (x10)	4000K		5000K		5700K	
	Initial Delivered Lumens*	BUG Ratings** Per TM-15-11	Initial Delivered Lumens*	BUG Ratings** Per TM-15-11	Initial Delivered Lumens*	BUG Ratings** Per TM-15-11
700mA						
12	21,643	B3 U1 G3	17,148	B3 U1 G3	22,476	B4 U1 G4
24	43,314	B4 U1 G4	34,318	B4 U1 G4	44,980	B5 U1 G5
1000mA						
12	29,064	B4 U1 G4	23,028	B3 U1 G3	30,182	B4 U1 G4
24	58,165	B5 U1 G5	46,084	B5 U1 G5	60,402	B5 U1 G5

* Initial delivered lumens at 25°C (77°F). Actual production yield may vary between -4 and +10% of initial delivered lumens
 ** For more information on the IES BUG (Backlight-Uplight-Glare) Rating visit: www.iesna.org/PDF/Erratas/TM-15-11BugRatingsAddendum.pdf. Valid with no tilt

Cree Edge™ High Output Area/Flood Luminaire

Photometry

All published luminaire photometric testing performed to IESNA LM-79-08 standards by a NVLAP certified laboratory. To obtain an IES file specific to your project consult: <http://www.cree.com/lighting>.

3MB

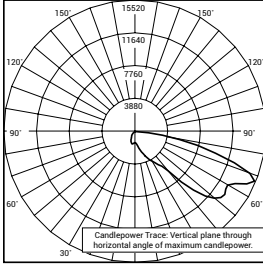

ITL Test Report #: 78733
 ARE EHO 3MB ** 12 E UL 1000
 Initial Delivered Lumens: 23,622

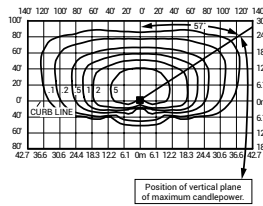

ARE EHO 3MB ** 24 E UL 1000 40K
 Mounting Height: 25' (7.6m) A.F.G.
 Initial Delivered Lumens: 43,026
 Initial FC at grade

Type III Medium w/BLS Distribution						
LED Count (x10)	4000K		5000K		5700K	
	Initial Delivered Lumens*	BUG Ratings** Per TM-15-11	Initial Delivered Lumens*	BUG Ratings** Per TM-15-11	Initial Delivered Lumens*	BUG Ratings** Per TM-15-11
700mA						
12	16,010	B2 U1 G3	12,685	B1 U1 G3	16,626	B2 U1 G3
24	32,041	B3 U1 G4	25,386	B2 U1 G4	33,273	B3 U1 G4
1000mA						
12	21,499	B2 U1 G4	17,034	B2 U1 G3	22,326	B2 U1 G4
24	43,026	B3 U1 G5	34,090	B3 U1 G4	44,681	B3 U1 G5

* Initial delivered lumens at 25°C (77°F). Actual production yield may vary between -4 and +10% of initial delivered lumens
 ** For more information on the IES BUG (Backlight-Uplight-Glare) Rating visit: www.iesna.org/PDF/Erratas/TM-15-11BugRatingsAddendum.pdf. Valid with no tilt

3MP

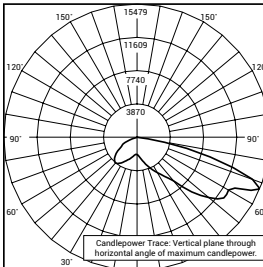

ITL Test Report #: 78644
 ARE EHO 3MP ** 12 E UL 1000 40K
 Initial Delivered Lumens: 25,997

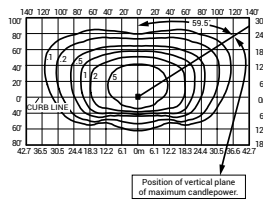

ARE EHO 3MP ** 24 E UL 1000 40K
 Mounting Height: 25' (7.6m) A.F.G.
 Initial Delivered Lumens: 50,994
 Initial FC at grade

Type III Medium w/Partial BLS Distribution						
LED Count (x10)	4000K		5000K		5700K	
	Initial Delivered Lumens*	BUG Ratings** Per TM-15-11	Initial Delivered Lumens*	BUG Ratings** Per TM-15-11	Initial Delivered Lumens*	BUG Ratings** Per TM-15-11
700mA						
12	18,975	B3 U1 G3	15,034	B2 U1 G2	19,705	B3 U1 G3
24	37,974	B3 U1 G4	30,087	B3 U1 G4	39,435	B3 U1 G4
1000mA						
12	25,481	B3 U1 G4	20,189	B3 U1 G3	26,461	B3 U1 G4
24	50,994	B4 U1 G5	40,403	B4 U1 G4	52,955	B4 U1 G5

* Initial delivered lumens at 25°C (77°F). Actual production yield may vary between -4 and +10% of initial delivered lumens
 ** For more information on the IES BUG (Backlight-Uplight-Glare) Rating visit: www.iesna.org/PDF/Erratas/TM-15-11BugRatingsAddendum.pdf. Valid with no tilt

Cree Edge™ High Output Area/Flood Luminaire

Photometry

All published luminaire photometric testing performed to IESNA LM-79-08 standards by a NVLAP certified laboratory. To obtain an IES file specific to your project consult: <http://www.cree.com/lighting>.

4M

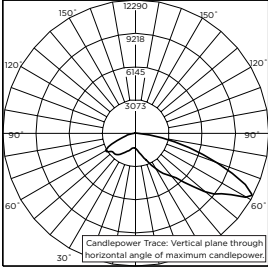

ITL Test Report #: 77685
 ARE EHO 4M ** 12 E UL 700 50K
 Initial Delivered Lumens: 19,507

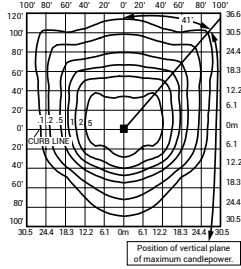

ARE EHO 4M ** 24 E UL 1000 40K
 Mounting Height: 25' (7.6m) A.F.G.
 Initial Delivered Lumens: 61,352
 Initial FC at grade

Type IV Medium Distribution						
LED Count (x10)	4000K		5000K		5700K	
	Initial Delivered Lumens*	BUG Ratings** Per TM-15-11	Initial Delivered Lumens*	BUG Ratings** Per TM-15-11	Initial Delivered Lumens*	BUG Ratings** Per TM-15-11
700mA						
12	22,829	B3 U1 G3	18,088	B3 U1 G3	23,707	B3 U1 G3
24	45,687	B5 U1 G4	36,199	B4 U1 G4	47,445	B5 U1 G4
1000mA						
12	30,656	B4 U1 G4	24,289	B3 U1 G3	31,835	B4 U1 G4
24	61,352	B5 U1 G5	48,609	B5 U1 G5	63,711	B5 U1 G5

* Initial delivered lumens at 25°C (77°F). Actual production yield may vary between -4 and +10% of initial delivered lumens
 ** For more information on the IES BUG (Backlight-Uplight-Glare) Rating visit: www.iesna.org/PDF/Erratas/TM-15-11BugRatingsAddendum.pdf. Valid with no tilt

4MB

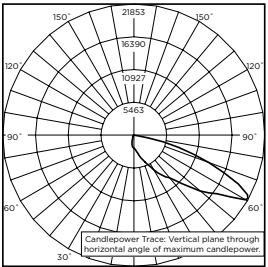

ITL Test Report #: 78734
 ARE EHO 4MB ** 12 E UL 1000 40K
 Initial Delivered Lumens: 25,113

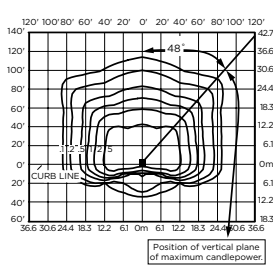

ARE EHO 4MB ** 24 E UL 1000 40K
 Mounting Height: 25' (7.6m) A.F.G.
 Initial Delivered Lumens: 46,213
 Initial FC at grade

Type IV Medium w/BLS Distribution						
LED Count (x10)	4000K		5000K		5700K	
	Initial Delivered Lumens*	BUG Ratings** Per TM-15-11	Initial Delivered Lumens*	BUG Ratings** Per TM-15-11	Initial Delivered Lumens*	BUG Ratings** Per TM-15-11
700mA						
12	17,196	B2 U1 G3	13,625	B1 U1 G2	17,857	B2 U1 G3
24	34,414	B2 U1 G4	27,266	B2 U1 G4	35,738	B3 U1 G4
1000mA						
12	23,092	B2 U1 G3	18,296	B2 U1 G3	23,980	B2 U1 G4
24	46,213	B3 U1 G5	36,615	B3 U1 G4	47,990	B3 U1 G5

* Initial delivered lumens at 25°C (77°F). Actual production yield may vary between -4 and +10% of initial delivered lumens
 ** For more information on the IES BUG (Backlight-Uplight-Glare) Rating visit: www.iesna.org/PDF/Erratas/TM-15-11BugRatingsAddendum.pdf. Valid with no tilt

Cree Edge™ High Output Area/Flood Luminaire

Photometry

All published luminaire photometric testing performed to IESNA LM-79-08 standards by a NVLAP certified laboratory. To obtain an IES file specific to your project consult: <http://www.cree.com/lighting>.

4MP

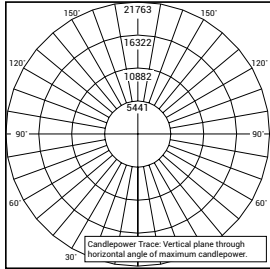

ITL Test Report #: 78967
ARE EHO 4MP ** 12 E UL 1000 40K
Initial Delivered Lumens: 28,934

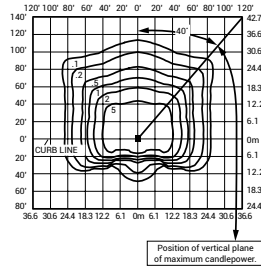

ARE EHO 4MP ** 24 E UL 1000 40K
Mounting Height: 25' (7.6m) A.F.G.
Initial Delivered Lumens: 54,181
Initial FC at grade

Type IV Medium w/Partial BLS Distribution

LED Count (x10)	4000K		5000K		5700K	
	Initial Delivered Lumens*	BUG Ratings** Per TM-15-11	Initial Delivered Lumens*	BUG Ratings** Per TM-15-11	Initial Delivered Lumens*	BUG Ratings** Per TM-15-11
700mA						
12	20,161	B3 U1 G3	15,974	B2 U1 G2	20,936	B3 U1 G3
24	40,347	4 U1 G4	31,968	B3 U1 G4	41,899	B4 U1 G4
1000mA						
12	27,073	B3 U1 G3	21,450	B3 U1 G3	28,114	B3 U1 G4
24	54,181	B4 U1 G5	42,928	B4 U1 G4	56,265	B4 U1 G5

* Initial delivered lumens at 25°C (77°F). Actual production yield may vary between -4 and +10% of initial delivered lumens
** For more information on the IES BUG (Backlight-Uplight-Glare) Rating visit: www.iesna.org/PDF/Erratas/TM-15-11BugRatingsAddendum.pdf. Valid with no tilt

5M

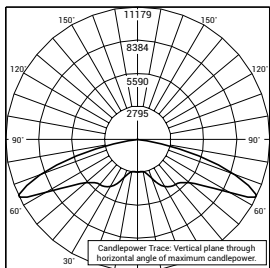

ITL Test Report #: 78580
ARE EHO 5M ** 12 E UL 1000 40K
Initial Delivered Lumens: 32,328

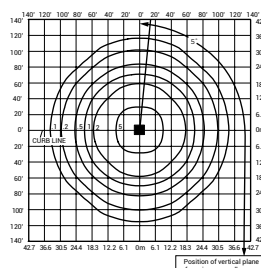

ARE EHO 5M ** 24 E UL 1000 40K
Mounting Height: 25' (7.6m) A.F.G.
Initial Delivered Lumens: 64,539
Initial FC at grade

Type V Medium Distribution

LED Count (x10)	4000K		5000K		5700K	
	Initial Delivered Lumens*	BUG Ratings** Per TM-15-11	Initial Delivered Lumens*	BUG Ratings** Per TM-15-11	Initial Delivered Lumens*	BUG Ratings** Per TM-15-11
700mA						
12	24,015	B5 U1 G3	19,027	B4 U1 G2	24,939	B5 U1 G3
24	48,061	B5 U1 G4	38,079	B5 U1 G4	49,909	B5 U1 G4
1000mA						
12	32,249	B5 U1 G4	25,551	B5 U1 G3	33,489	B5 U1 G4
24	64,539	B5 U1 G5	51,135	B5 U1 G5	67,021	B5 U1 G5

* Initial delivered lumens at 25°C (77°F). Actual production yield may vary between -4 and +10% of initial delivered lumens
** For more information on the IES BUG (Backlight-Uplight-Glare) Rating visit: www.iesna.org/PDF/Erratas/TM-15-11BugRatingsAddendum.pdf. Valid with no tilt

Cree Edge™ High Output Area/Flood Luminaire

Photometry

All published luminaire photometric testing performed to IESNA LM-79-08 standards by a NVLAP certified laboratory. To obtain an IES file specific to your project consult: <http://www.cree.com/lighting>.

5S

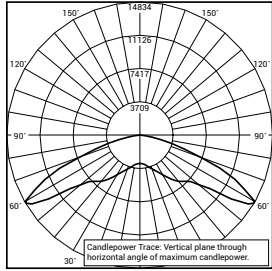

ITL Test Report #: 78687
ARE EHO 5S ** 12 E UL 1000 40K
Initial Delivered Lumens: 37,329

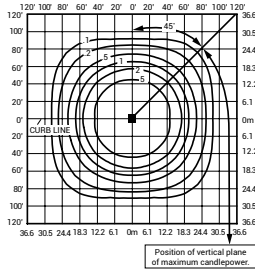

ARE EHO 5S ** 24 E UL 1000 40K
Mounting Height: 25' (7.6m) A.F.G.
Initial Delivered Lumens: 71,710
Initial FC at grade

Type V Short Distribution						
LED Count (x10)	4000K		5000K		5700K	
	Initial Delivered Lumens*	BUG Ratings** Per TM-15-11	Initial Delivered Lumens*	BUG Ratings** Per TM-15-11	Initial Delivered Lumens*	BUG Ratings** Per TM-15-11
700mA						
12	26,684	B4 U0 G2	21,142	B4 U1 G2	27,710	B5 U0 G3
24	53,401	B5 U0 G4	42,310	B5 U1 G4	55,455	B5 U0 G4
1000mA						
12	35,832	B5 U0 G3	28,390	B5 U1 G3	37,210	B5 U0 G3
24	71,710	B5 U0 G5	56,816	B5 U1 G4	74,468	B5 U0 G5

* Initial delivered lumens at 25°C (77°F). Actual production yield may vary between -4 and +10% of initial delivered lumens
** For more information on the IES BUG (Backlight-Uplight-Glare) Rating visit: www.iesna.org/PDF/Erratas/TM-15-11BugRatingsAddendum.pdf. Valid with no tilt

AF

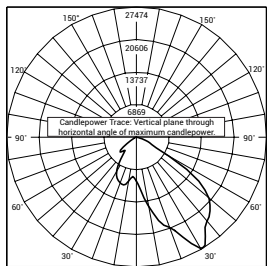

ITL Test Report #: 78579
ARE EHO AF ** 12 E UL 1000 40K
Initial Delivered Lumens: 36,341

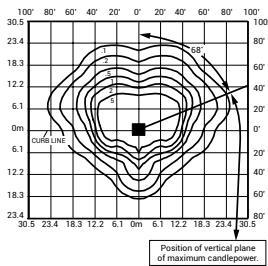

ARE EHO AF ** 24 E UL 1000 40K
Mounting Height: 25' (7.6m) A.F.G.
Initial Delivered Lumens: 69,319
Initial FC at grade

Automotive FrontlineOptic™ Distribution						
LED Count (x10)	4000K		5000K		5700K	
	Initial Delivered Lumens*	BUG Ratings** Per TM-15-11	Initial Delivered Lumens*	BUG Ratings** Per TM-15-11	Initial Delivered Lumens*	BUG Ratings** Per TM-15-11
700mA						
12	25,794	B3 U0 G2	20,437	B3 U0 G1	26,786	B3 U0 G2
24	51,621	B4 U0 G2	40,900	B4 U0 G2	53,606	B4 U0 G2
1000mA						
12	34,638	B4 U0 G2	27,444	B3 U0 G2	35,970	B4 U0 G2
24	69,319	B5 U0 G3	54,922	B4 U0 G2	71,986	B5 U0 G3

* Initial delivered lumens at 25°C (77°F). Actual production yield may vary between -4 and +10% of initial delivered lumens
** For more information on the IES BUG (Backlight-Uplight-Glare) Rating visit: www.iesna.org/PDF/Erratas/TM-15-11BugRatingsAddendum.pdf. Valid with no tilt



Cree Edge™ High Output Area/Flood Luminaire

Photometry

All published luminaire photometric testing performed to IESNA LM-79-08 standards by a NVLAP certified laboratory. To obtain an IES file specific to your project consult: <http://www.cree.com/lighting>.

15'

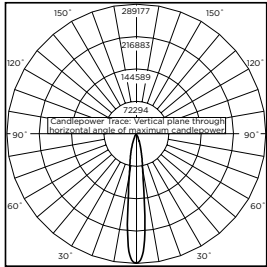

ITL Test Report #: 78519
 FLD EHO 15 ** 24 E UL 1000 40K
 Initial Delivered Lumens: 38,859

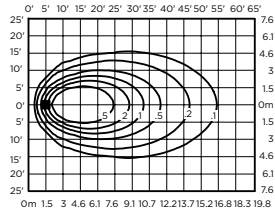

FLD EHO 15 ** 24 E UL 1000 40K
 Mounting Height: 25' (7.6m) A.F.G. - 60° tilt
 Initial Delivered Lumens: 73,303
 Initial FC at grade

15' Flood Optic Distribution

LED Count (x10)	4000K	5000K	5700K
	Initial Delivered Lumens*	Initial Delivered Lumens*	Initial Delivered Lumens*
700mA			
12	27,276	21,611	28,326
24	54,588	43,250	56,687
1000mA			
12	36,628	29,021	38,037
24	73,303	58,079	76,123

* Initial delivered lumens at 25°C (77°F). Actual production yield may vary between -4 and +10% of initial delivered lumens

25'

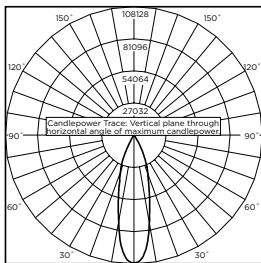

ITL Test Report #: 78520
 FLD EHO 25 ** 24 E UL 1000 40K
 Initial Delivered Lumens: 38,828

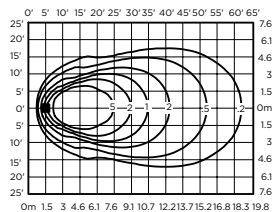

FLD EHO 25 ** 24 E UL 1000 40K
 Mounting Height: 25' (7.6m) A.F.G. - 60° tilt
 Initial Delivered Lumens: 73,303
 Initial FC at grade

25' Flood Optic Distribution

LED Count (x10)	4000K	5000K	5700K
	Initial Delivered Lumens*	Initial Delivered Lumens*	Initial Delivered Lumens*
700mA			
12	27,276	21,611	28,326
24	54,588	43,250	56,687
1000mA			
12	36,628	29,021	38,037
24	73,303	58,079	76,123

* Initial delivered lumens at 25°C (77°F). Actual production yield may vary between -4 and +10% of initial delivered lumens

Cree Edge™ High Output Area/Flood Luminaire

Photometry

All published luminaire photometric testing performed to IESNA LM-79-08 standards by a NVLAP certified laboratory. To obtain an IES file specific to your project consult: <http://www.cree.com/lighting>.

40°

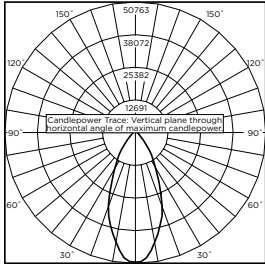

ITL Test Report #: 78521
 FLD EHO 40 ** 12 E UL 1000 40K
 Initial Delivered Lumens: 36,476

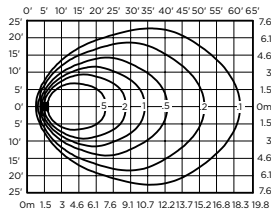

FLD EHO 40 ** 24 E UL 1000 40K
 Mounting Height: 25' (7.6m) A.F.G. - 60° tilt
 Initial Delivered Lumens: 71,710
 Initial FC at grade

40° Flood Optic Distribution			
LED Count (x10)	4000K	5000K	5700K
	Initial Delivered Lumens*	Initial Delivered Lumens*	Initial Delivered Lumens*
700mA			
12	26,684	21,142	27,710
24	53,401	42,310	55,455
1000mA			
12	35,832	28,390	37,210
24	71,710	56,816	74,468

* Initial delivered lumens at 25°C (77°F). Actual production yield may vary between -4 and +10% of initial delivered lumens

70°

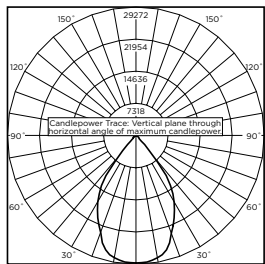

ITL Test Report #: 78522
 FLD EHO 70 ** 12 E UL 1000 40K
 Initial Delivered Lumens: 33,030

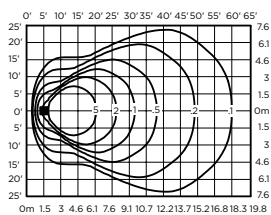

FLD EHO 70 ** 24 E UL 1000 40K
 Mounting Height: 25' (7.6m) A.F.G. - 60° tilt
 Initial Delivered Lumens: 65,336
 Initial FC at grade

70° Flood Optic Distribution			
LED Count (x10)	4000K	5000K	5700K
	Initial Delivered Lumens*	Initial Delivered Lumens*	Initial Delivered Lumens*
700mA			
12	24,312	19,262	25,247
24	48,654	38,549	50,525
1000mA			
12	32,647	25,867	33,903
24	65,336	51,766	67,849

* Initial delivered lumens at 25°C (77°F). Actual production yield may vary between -4 and +10% of initial delivered lumens

Cree Edge™ High Output Area/Flood Luminaire

Photometry

All published luminaire photometric testing performed to IESNA LM-79-08 standards by a NVLAP certified laboratory. To obtain an IES file specific to your project consult: <http://www.cree.com/lighting>.

SN

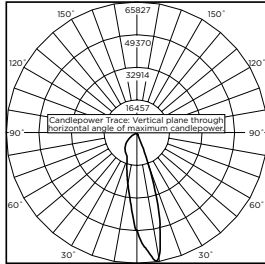

ITL Test Report #: 78563
FLD EHO SN ** 24 E UL 1000 40K
Initial Delivered Lumens: 34,961

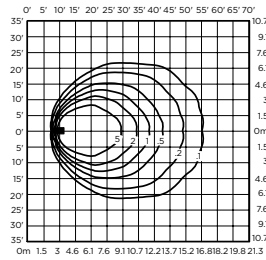

FLD EHO SN ** 24 E UL 1000 40K
Mounting Height: 25' (7.6m) A.F.G. - 60° tilt
Initial Delivered Lumens: 66,132
Initial FC at grade

Sign Optic Distribution			
LED Count (x10)	4000K	5000K	5700K
	Initial Delivered Lumens*	Initial Delivered Lumens*	Initial Delivered Lumens*
700mA			
12	24,608	19,497	25,555
24	49,248	39,019	51,142
1000mA			
12	33,045	26,182	34,316
24	66,132	52,397	68,676

* Initial delivered lumens at 25°C (77°F). Actual production yield may vary between -4 and +10% of initial delivered lumens

N6

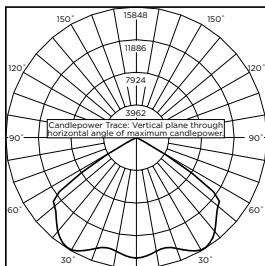

ITL Test Report #: 78562
FLD EHO N6 ** 12 E UL 1000 40K
Initial Delivered Lumens: 38,110

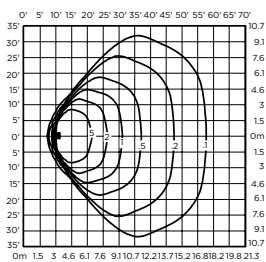











FLD EHO N6 ** 24 E UL 1000 40K
Mounting Height: 25' (7.6m) A.F.G. - 60° tilt
Initial Delivered Lumens: 73,303
Initial FC at grade

NEMA 6 Distribution			
LED Count (x10)	4000K	5000K	5700K
	Initial Delivered Lumens*	Initial Delivered Lumens*	Initial Delivered Lumens*
700mA			
12	27,276	21,611	28,326
24	54,588	43,250	56,687
1000mA			
12	36,628	29,021	38,037
24	73,303	58,079	76,123

* Initial delivered lumens at 25°C (77°F). Actual production yield may vary between -4 and +10% of initial delivered lumens

Cree Edge™ High Output Area/Flood Luminaire

Luminaire EPA

Horizontal/Vertical Tenon Mount and EHO-UNV Direct Mount Bracket											
LED Count (x10)	Luminaire Weight	Single	2 @ 90°	2 @ 180°	2 @ 180°	3 @ 90°	3 @ 120°	3 @ 180°	4 @ 90°	4 @ 180°	
Tenon Configuration If used with Cree tenons, please add tenon EPA with Luminaire EPA											
	Vertical	Horizontal	Vertical	Vertical	Vertical	Vertical	Vertical	Vertical	Vertical	Vertical	
	 PB-1A*; PW-1A3; EHO-UNV	 Horizontal Tenon	 PB-2A*; PB-2R2.375; PW-2A3; (2) EHO-UNV	 PB-2A*; PB-2R2.375; PW-2A3 (picture does not apply)	 PB-2A*; PB-2R2.375; PW-2A3 (picture doesn't apply)	 PB-3A*; PB-3R2.375; (3) EHO-UNV	 PB-3A*; PB-3R2.375	 PB-3A*; PB-3R2.375	 PB-4A*(90); PB-4R2.375; (4) EHO-UNV	 PB-4A*(180); PB-4R2.375	
0° Tilt											
12	45.3 lbs. (20.6kg)	1.41	1.41	2.35	2.83	2.83	3.76	3.76	4.24	4.70	5.66
24	80.5 lbs. (36.6kg)	1.41	1.41	2.80	2.83	N/A	4.22	4.22	N/A	5.61	N/A
10° Tilt											
12	45.3 lbs. (20.6kg)	1.49	1.41	2.90	2.98	2.98	4.39	4.39	5.96	5.81	7.95
24	80.5 lbs. (36.6kg)	2.38	1.97	2.38	4.76	N/A	6.18	6.18	N/A	7.59	N/A
20° Tilt											
12	45.3 lbs. (20.6kg)	2.11	1.71	3.53	4.22	4.22	5.64	5.64	8.45	7.05	11.26
24	80.5 lbs. (36.6kg)	3.46	3.11	4.87	6.92	N/A	7.12	7.12	N/A	9.74	N/A
30° Tilt											
12	45.3 lbs. (20.6kg)	2.69	2.30	4.11	5.39	5.39	6.80	6.80	10.78	8.22	14.37
24	80.5 lbs. (36.6kg)	4.59	4.23	6.97	9.19	N/A	10.60	10.60	N/A	12.01	N/A
45° Tilt											
12	45.3 lbs. (20.6kg)	3.50	3.11	4.91	6.99	6.99	8.40	8.40	13.98	9.82	18.64
24	80.5 lbs. (36.6kg)	6.03	5.73	7.44	10.31	N/A	13.48	13.48	N/A	14.89	N/A
60° Tilt											
12	45.3 lbs. (20.6kg)	4.12	3.74	5.54	8.25	8.25	9.66	9.66	16.49	11.08	21.99
24	80.5 lbs. (36.6kg)	7.24	6.91	8.65	12.37	N/A	15.89	15.89	N/A	17.30	N/A
70° Tilt											
12	45.3 lbs. (20.6kg)	4.41	4.03	5.83	8.83	8.83	10.24	10.24	17.65	11.65	23.54
24	80.5 lbs. (36.6kg)	7.76	7.45	9.17	15.51	N/A	16.93	16.93	N/A	18.34	N/A
80° Tilt											
12	45.3 lbs. (20.6kg)	4.59	4.21	6.00	9.18	9.18	10.59	10.59	18.36	12.01	24.47
24	80.5 lbs. (36.6kg)	8.06	7.79	9.48	16.12	N/A	17.54	17.54	N/A	18.95	N/A
90° Tilt											
12	45.3 lbs. (20.6kg)	4.64	4.26	6.06	9.29	9.29	10.70	10.70	18.58	12.12	24.77
24	80.5 lbs. (36.6kg)	8.14	7.89	9.56	16.29	N/A	17.70	17.70	N/A	19.12	N/A

Note: Not for use with aluminum tenons



Cree Edge™ High Output Area/Flood Luminaire

Tenon EPA

Part Number	EPA
PB-1A*	None
PB-2A*	0.82
PB-3A*	1.52
PB-4A*(90)	1.11
PB-4A*(180)	2.22
PB-2R2.375	0.92
PB-3R2.375	1.62
PB-4R2.375	2.32
PW-1A3**	0.47
PW-2A3**	0.94
WM-2	0.08
WM-2L	0.13
WM-4L	0.32

Tenons and Brackets (must specify color)	
Square Internal Mount Vertical Tenons (Steel) - Mounts to 3-6" (76-152mm) square aluminum or steel poles PB-1A* - Single PB-4A*(90) - 90° Quad PB-2A* - 180° Twin PB-4A*(180) - 180° Quad PB-3A* - 180° Triple	Round Internal Mount Vertical Tenons (Steel) - Mounts to 2.375" (60mm) O.D. round aluminum or steel poles or tenons PB-2R2.375 - Twin PB-4R2.375 - Quad PB-3R2.375 - Triple
Wall Mount Brackets - Mounts to wall, roof or side of wood pole WM-2 - Horizontal WM-4L - L-Shape WM-2L - Extended Horizontal	Mid-Pole Bracket - Mounts to square pole PW-1A3** - Single PW-2A3** - Double

* Specify pole size: 3 (3"), 4 (4"), 5 (5"), or 6 (6") for single, double or triple luminaire orientation or 4 (4"), 5 (5"), or 6 (6") for quad luminaire orientation
 ** These EPA values must be multiplied by the following ratio: Fixture Mounting Height/Total Pole Height

Direct Mount Configurations

Compatibility with EHO-UNV Direct Mount Bracket					
LED Count (x10)	2 @ 90°	2 @ 180°	3 @ 90°	3 @ 120°	4 @ 90°
4" Square					
12	✓	✓	N/A	N/A	N/A
24	✓	✓	N/A	N/A	N/A
4" Round					
12	N/A	✓	N/A	N/A	N/A
24	N/A	✓	N/A	N/A	N/A
5" Square					
12	✓	✓	✓	N/A	✓
24	✓	✓	✓	N/A	✓
5" Round					
12	N/A	✓	N/A	✓	N/A
24	N/A	✓	N/A	✓	N/A
6" Square					
12	✓	✓	✓	N/A	✓
24	✓	✓	✓	N/A	✓
6" Round					
12	✓	✓	✓	✓	✓
24	✓	✓	✓	✓	✓

© 2014 Cree, Inc. All rights reserved. For informational purposes only. Content is subject to change. See www.cree.com/patents for patents that cover these products. Cree®, the Cree logo, BetaLED®, NanoOptic®, the BetaLED Technology logo, TrueWhite®, Cree TrueWhite®, the Cree TrueWhite Technology logo, and Colorfast DeltaGuard® are registered trademarks, and Cree Edge™ and Automotive FrontlineOptic™ are trademarks of Cree, Inc. The UL logo is a registered trademark of UL LLC. NEMA® is a registered trademark of the National Electrical Manufacturers Association. The DesignLights Consortium logo and the DLC QPL Listed logo are registered trademarks of Northeast Energy Efficiency Partnerships, Inc.



LED Multi-Level Options

For use with Cree Edge™, LEDway®, LEDway SLM™, SLM IP66, 227 Series™, 228 Series™, 304 Series, CPY Series, and VG Series Luminaires

Product Description:

The Cree® Multi-Level options allow multiple operating drive currents for high and low dimming modes. The multi-level option includes a sensor integrated into the luminaire and is designed to operate all LEDs at the same drive current for maximum and uniform life.

The occupancy sensor uses passive infrared technology that reacts to changes in infrared energy (moving heat) within the coverage area of the sensor. When motion is detected the luminaire is switched to high mode. After motion is no longer detected and the time delay cycle has been completed, the luminaire is returned to its low mode setting. The sensor itself includes eight possible field adjustable settings for each of the following categories: Ambient, Time Delay, High Dimming and Low Dimming.

Ambient Light feature (A) is factory set at "OSO" which eliminates any daylight harvesting management and allows the fixture to operate only on occupancy. The Ambient Light feature includes eight possible field settings:

Occupancy Sensing Only (OSO):

Occupancy detection (PIR) enabled only. Ambient Light sensing is disabled. The sensor will switch the luminaire to High mode during occupancy detection regardless of environment light levels. After motion is no longer detected and the time delay cycle has been completed, the luminaire returned to its low mode setting.

Occupancy Sensing and Time Off (OSTO):

Occupancy detection (PIR) enabled only with Time Off operation. Ambient light sensing is disabled. The sensor will switch the luminaire to High mode during occupancy detection regardless of environment light levels. After motion is no longer detected and the time delay cycle has been completed, the luminaire returned to its low mode setting. Sensor will switch the luminaire to Off after 30 minutes of no occupancy detection (Low mode).

Occupancy Sensing and Low Ambient (OSLA):

Occupancy detection (PIR) and Ambient Light sensing enabled. When environment light levels exceed 130 Lux (12 FC), luminaire will remain Off regardless of occupancy. If environment light levels are below 80 Lux (7 FC), luminaire will remain in Low mode during no occupancy and switch to High mode after occupancy is detected.

Occupancy Sensing and High Ambient (OSHA):

Occupancy detection (PIR) and Ambient Light sensing enabled. When environment light levels exceed 600 Lux (55 FC), luminaire will remain Off regardless of occupancy. If environment light levels are below 500 Lux (46 FC), luminaire will remain in Low mode during no occupancy and switch to High mode after occupancy is detected.

Occupancy Sensing, Low Ambient and Time Off (OSLATO):

Occupancy detection (PIR), Ambient Light sensing and Time Off enabled. When environment light levels exceed 130 Lux (12 FC), luminaire will remain Off regardless of occupancy. If environment light levels are below 80 Lux (7 FC) and occupancy is detected, luminaire will switch to High mode. After motion is no longer detected and the time delay cycle has been completed, the luminaire returned to its low mode setting. Sensor will switch the luminaire Off after 30 minutes of no occupancy detection (Low mode).

Occupancy Sensing, High Ambient and Time Off (OSHATO):

Occupancy detection (PIR), Ambient Light sensing and Time Off enabled. When environment light levels exceed 600 Lux (55 FC), luminaire will remain Off regardless of occupancy. If environment light levels are below 500 Lux (46 FC) and occupancy is detected, luminaire will switch to High mode. After motion is no longer detected and the time delay cycle has been completed, the luminaire returned to its low mode setting. Sensor will switch the luminaire Off after 30 minutes of no occupancy detection (Low mode). The following features are used to bypass sensor:

Lock Low Mode (LL):

Sensor locks in Low Dimming level indefinitely. The occupancy detection (PIR) and Ambient Light operation are disabled during the Lock Low mode. Typically used for test mode.

Lock High Mode (LH):

Sensor turns the fixture on at the low level set by setting. Sensor will cycle every 5 seconds between specified Low and High dimming settings for 4 complete cycles (Low, High, Low, High) and then locks in High indefinitely. The occupancy detection (PIR) and Ambient Light operation are disabled during the Lock High mode. Typically used for test mode.

Time Delay feature (D) can be adjusted from 0.5 min to 30 min. and is factory set at 4 min. Once motion is detected, the lighting load will remain in the High Mode until motion is no longer detected and the time delay cycle has been completed.

Low Dimming feature (L) can be adjusted from an off position to a maximum drive current of 325mA and is factory set at 75mA.

High Dimming feature (H) can be adjusted from a 350mA drive current to a maximum drive current of 700mA and is factory set at 525mA. Please note some luminaires may be rated for 525mA maximum drive current. .

Figure 1 - LEDway Streetlights, LEDway SLM Streetlights, SLM IP66 Street and Area Luminaires, and Cree Edge Flood and Area Luminaires, Cree Edge High Output Flood and Area Luminaires

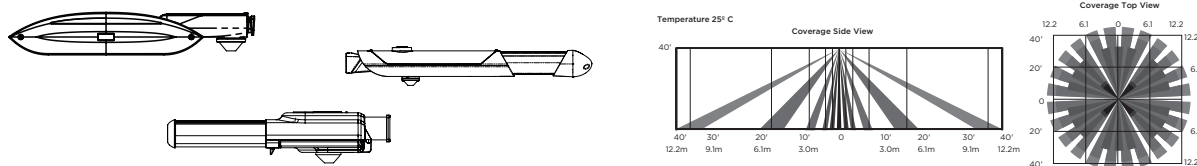

Figure 2 - Cree Edge Canopy, Cree Edge Round Area, 304 Series Canopy, 227 Series Recessed Upgrade, 228 Series Recessed Canopy, and CPY250 Canopy / Soffit Luminaires

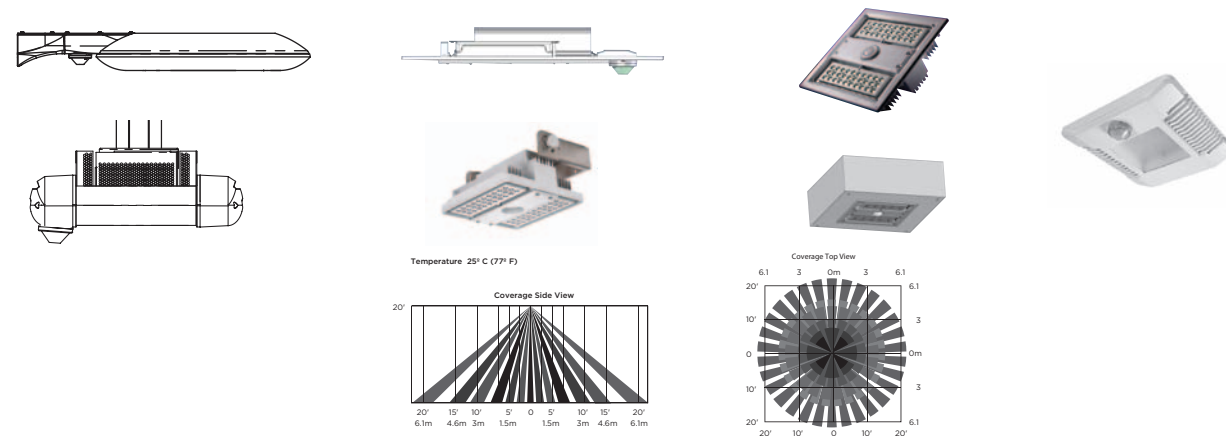
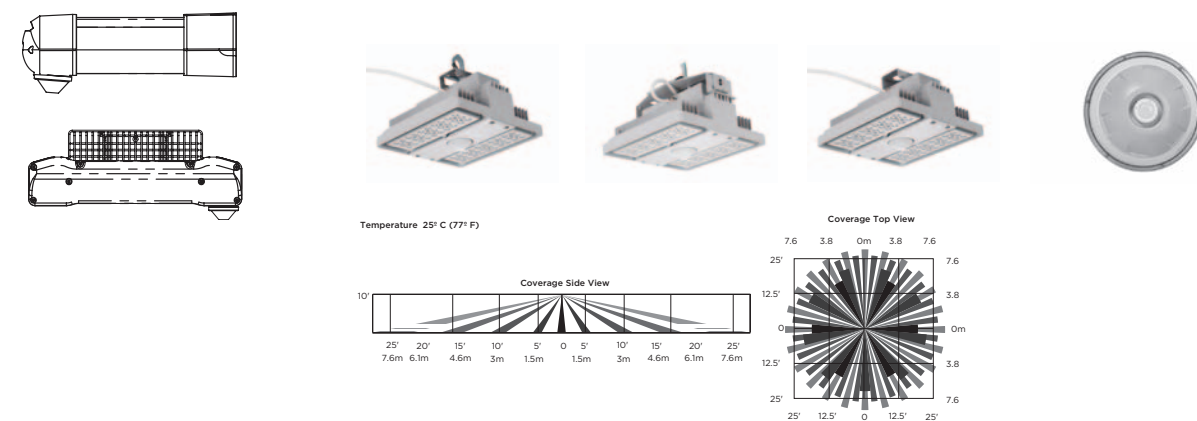

Figure 3 - Cree Edge Security, Cree Edge Parking Structure, 304 Series Parking Structure, and VG Series Vehicle Garage Luminaires



Sensor Details	
Luminaire	Lens
LEDway Streetlights, LEDway SLM Streetlights, SLM IP66 Street and Area Luminaires, Cree Edge Flood and Area Luminaires, Cree Edge High Output Flood and Area Luminaires	Lens coverage: 30' (9.1m) optimal mounting height and 60' (18.3m) diameter coverage with a 360° circular pattern. The minimum and maximum mounting heights are 20' (6.1m) 40' (12.2m) respectively. Lens mounting height to coverage radius is 1:1. See Figure 1. Note: When mounting heights are above 30' (9.1m), the sensor only detects large objects such as fork lift trucks or cars.
Cree Edge Canopy, Cree Edge Round Area, 304 Series Canopy, 227 Series Recessed Upgrade, 228 Series Recessed Canopy, and CPY250 Canopy / Soffit Luminaires	Lens coverage: 20' (6.1m) optimal mounting height and 40' (12.2m) diameter coverage area with a 360° circular pattern. The minimum and maximum mounting heights are 10' (3m) and 30' (9.1m) respectively. Lens mounting height to coverage radius is 1:1. See Figure 2.
Cree Edge Security, Cree Edge Parking Structure, 304 Series Parking Structure, and VG Series Vehicle Garage Luminaires	Lens coverage: 10' (3m) optimal mounting height and 50' (15.2m) diameter coverage area with a 360° circular pattern. The maximum mounting height is 15' (4.6m). Lens mounting height to coverage radius is 1:2.5. See Figure 3.



LED Multi-Level Options

Product Availability

Cree Edge Luminaire Availability										
Drive Current	Voltage	Area			Area Round ¹	Canopy	Interior Round ¹	Parking ¹	Pathway ¹	Security
		Direct & Adjustable Arm Mounts	Post Top Mounts	SA Mounts	Direct & Adjustable Arm Mounts	All Mounts	All Mounts	All Mounts	All Mounts	Wall Mount
350	120-277	20-160 LEDs ^{F,PR}	40-160 LEDs ^{F,P}	N/A	40-120 LEDs ^F	40-160 LEDs ^{F,P}	N/A	40-100 LEDs ^F	N/A	20-80 LEDs ^F
	347-480	20-160 LEDs	40-80 LEDs	N/A	N/A	N/A	N/A	N/A	N/A	N/A
525	120-277	20-160 LEDs ^{F,PR}	40-160 LEDs ^{F,P}	N/A	40-120 LEDs ^F	40-160 LEDs ^{F,P}	N/A	40-100 LEDs ^F	N/A	20-80 LEDs ^F
	347-480	20-160 LEDs	40-80 LEDs	N/A	N/A	N/A	N/A	N/A	N/A	N/A
700	120-277	20-60 LEDs ^{F,PR}	40-60 LEDs ^{F,P}	N/A	40-60 LEDs ^F	40-60 LEDs ^{F,P}	N/A	40-60 LEDs ^F	N/A	20-80 LEDs ^F
	347-480	20-60 LEDs	40-60 LEDs	N/A	N/A	N/A	N/A	N/A	N/A	N/A

¹ Consult Area Round / Pathway / Interior Round Multi-Level spec sheet for availability.

^F Multi-Level option available with Fusing option.

^P Multi-Level option available with Photocell option.

^R Multi-Level option available with NEMA Photocell Receptacle option.

LEDway Luminaire Availability					
Drive Current	Voltage	LEDway Streetlight		LEDWay SLM Streetlight	SLM IP66 Streetlight
		Horizontal Tenon Mount	IP66 Rated Mounts	Horizontal Tenon Mount	All Mounts
350	120-277	N/A	20-120 LEDs ^{F,R}	N/A	N/A
	347-480	N/A	N/A	N/A	N/A
525	120-277	N/A	20-120 LEDs ^{F,R}	N/A	20-60 LEDs ^{F,R}
	347-480	N/A	N/A	N/A	N/A
700	120-277	N/A	20-120 LEDs ^{F,R}	N/A	20-60 LEDs ^{F,R}
	347-480	N/A	N/A	N/A	N/A
1000	120-277	N/A	N/A	N/A	20-40 LEDs ^{F,R}
	347-480	N/A	N/A	N/A	N/A

^F Multi-Level option available with Fusing option.

^R Multi-Level option available with Receptacle option.

304 Series Luminaire Availability										
Drive Current	Voltage	Canopy			Parking Structure	Floodlight	Interior		Soffit	
		Recessed Mount for Single Skin Canopies	Recessed Mount for Double Skin Canopies	Recessed Upgrade Kit Mounts	All Mounts	Yoke Mounts	Recessed Mount	IC Rated Recessed Mount	Recessed Mount	IC Rated Recessed Mount
350	120-277	40-60 LEDs ^F	40-60 LEDs ^F	40-60 LEDs ^F	40-60 LEDs ^F	40-60 LEDs ^F	40-60 LEDs ^F	N/A	40-60 LEDs ^F	N/A
	347-480	N/A	N/A	N/A	N/A	N/A	N/A	N/A	N/A	N/A
525	120-277	40-60 LEDs ^F	40-60 LEDs ^F	40-60 LEDs ^F	40-60 LEDs ^F	40-60 LEDs ^F	40-60 LEDs ^F	N/A	40-60 LEDs ^F	N/A
	347-480	N/A	N/A	N/A	N/A	N/A	N/A	N/A	N/A	N/A
700	120-277	40-60 LEDs ^F	40-60 LEDs ^F	N/A	40-60 LEDs ^F	40-60 LEDs ^F	N/A	N/A	N/A	N/A
	347-480	N/A	N/A	N/A	N/A	N/A	N/A	N/A	N/A	N/A

^F Multi-Level option available with Fusing option.

228 Series Luminaire Availability					
Drive Current	Voltage	Canopy		Soffit	
		Recessed Mount	Recessed Upgrade Kit Mounts	Recessed Mount	IC Rated Recessed Mount
350	120-277	90 LEDs	N/A	30, 60 LEDs	N/A
	347-480	N/A	N/A	N/A	N/A
525	120-277	30, 60, 90 LEDs	30, 60 LEDs	30, 60 LEDs	N/A
	347-480	N/A	N/A	N/A	N/A
700	120-277	30, 60, 90 ¹ LEDs	30, 60 LEDs	N/A	N/A
	347-480	N/A	N/A	N/A	N/A
900	120-277	60 LEDs ¹	N/A	N/A	N/A
	347-480	N/A	N/A	N/A	N/A
1000	120-277	30 LEDs ¹	N/A	N/A	N/A
	347-480	N/A	N/A	N/A	N/A

¹ Requires marked spacing 48" (1,219mm) x 24" (610mm) x 6" (152mm); 48" (1,219mm) luminaire to luminaire, 24" (610mm) luminaire to side wall, 6" (152mm) above luminaire.



Product Availability Continued

VG Series Luminaires		
Input Power Designator	Voltage	Availability
A	120-277	Available
	347, 480	Available

CPY250 Luminaires		
Input Power Designator	Voltage	Availability
A	120-277	N/A
	347- 480	N/A
B	120-277	Available
	347-480	N/A

350mA Drive Current

Note: For use with products when 350mA drive current is specified. Specified drive current represents the maximum drive current that will be available with dimming option. Specifying the maximum allowed drive current for your product will provide the greatest range of dimming. Multipliers are for estimating purposes only. Check actual spec sheet data where available.

Low Dimming Settings								
120-277V					347-480V			
Position	0-10V	Drive Current	System Watts Multiplier	Lumen Multiplier	0-10V	Drive Current	System Watts Multiplier	Lumen Multiplier
0	0	OFF	0	0	0	OFF	0	0
1	1.3	75	0.15	0.15	1.0	38	0.10	0.11
2	2.1	125	0.26	0.27	1.7	63	0.17	0.18
3	2.5	150	0.31	0.31	2.0	75	0.20	0.22
4	2.8	175	0.36	0.37	2.3	88	0.23	0.29
5	3.6	225	0.45	0.45	2.8	113	0.31	0.35
6	4.4	275	0.55	0.53	3.4	138	0.38	0.41
7	5.1	325	0.64	0.62	4.0	163	0.45	0.48

High Dimming Settings								
120-277V					347-480V			
Position	0-10V	Drive Current	System Watts Multiplier	Lumen Multiplier	0-10V	Drive Current	System Watts Multiplier	Lumen Multiplier
0	5.5	350	0.67	0.70	4.2	175	0.49	0.52
1	6.7	425	0.83	0.80	5.1	213	0.59	0.60
2	7.5	475	0.92	0.89	5.6	238	0.66	0.66
3	8.7	525	1.00	1.00	6.2	263	0.74	0.73
4	8.7	525	1.00	1.00	6.5	275	0.77	0.76
5	8.7	525	1.00	1.00	6.8	288	0.81	0.79
6	8.7	525	1.00	1.00	7.3	313	0.88	0.85
7	8.7	525	1.00	1.00	8.4	350	1.00	1.00

Factory Dimming Settings		
ML Option	Low Dimming Setting	High Dimming Setting
ML4 (HL)	75mA	350mA
ML5 (HK)	175mA	350mA

525mA Drive Current

Note: For use with products when 525mA drive current is specified. Specified drive current represents the maximum drive current that will be available with dimming option. Specifying the maximum allowed drive current for your product will provide the greatest range of dimming. Multipliers are for estimating purposes only. Check actual spec sheet data where available.

Low Dimming Settings								
120-277V					347-480V			
Position	0-10V	Drive Current	System Watts Multiplier	Lumen Multiplier	0-10V	Drive Current	System Watts Multiplier	Lumen Multiplier
0	0	OFF	0.00	0.00	0	OFF	0.00	0.00
1	1.3	75	0.15	0.15	1.3	75	0.15	0.15
2	2.1	125	0.26	0.27	2.1	125	0.26	0.27
3	2.5	150	0.31	0.31	2.5	150	0.31	0.31
4	2.8	175	0.36	0.37	2.8	175	0.45	0.45
5	3.6	225	0.45	0.45	3.6	225	0.45	0.45
6	4.4	275	0.55	0.53	4.4	275	0.55	0.53
7	5.1	325	0.64	0.62	5.1	325	0.64	0.62

Factory Dimming Settings		
ML Option	Low Dimming Setting	High Dimming Setting
ML (CL)	75mA	525mA
ML1 (CK)	175mA	525mA



525mA Drive Current Continued

Note: For use with products when 525mA drive current is specified. Specified drive current represents the maximum drive current that will be available with dimming option. Specifying the maximum allowed drive current for your product will provide the greatest range of dimming. Multipliers are for estimating purposes only. Check actual spec sheet data where available.

High Dimming Settings								
120-277V					347-480V			
Position	0-10V	Drive Current	System Watts Multiplier	Lumen Multiplier	0-10V	Drive Current	System Watts Multiplier	Lumen Multiplier
0	6	350	0.67	0.70	5.5	350	0.67	0.70
1	6.7	425	0.83	0.80	6.7	425	0.83	0.80
2	7.5	475	0.92	0.89	7.5	475	0.82	0.89
3	8.7	525	1.00	1.00	8.7	525	1.00	1.00
4	8.7	525	1.00	1.00	8.7	525	1.00	1.00
5	8.7	525	1.00	1.00	8.7	525	1.00	1.00
6	8.7	525	1.00	1.00	8.7	525	1.00	1.00
7	8.7	525	1.00	1.00	8.7	525	1.00	1.00

700mA Drive Current

Note: For use with products when 700mA drive current is specified. Specified drive current represents the maximum drive current that will be available with dimming option. Specifying the maximum allowed drive current for your product will provide the greatest range of dimming. Multipliers are for estimating purposes only. Check actual spec sheet data where available.

Low Dimming Settings								
120-277V					347-480V			
Position	0-10V	Drive Current	System Watts Multiplier	Lumen Multiplier	0-10V	Drive Current	System Watts Multiplier	Lumen Multiplier
0	0.0	OFF	0.00	0.00	0.0	OFF	0.0	0.0
1	1.2	75	0.11	0.12	1.2	75	0.14	0.12
2	1.7	125	0.19	0.21	1.7	125	0.19	0.21
3	2.0	150	0.23	0.25	2.0	150	0.23	0.25
4	2.3	175	0.26	0.29	2.3	175	0.26	0.29
5	2.8	225	0.32	0.35	2.8	225	0.33	0.35
6	3.4	275	0.40	0.42	3.4	275	0.40	0.42
7	4.0	325	0.78	0.49	4.0	325	0.47	0.49

High Dimming Settings								
120-277V					347-480V			
Position	0-10V	Drive Current	System Watts Multiplier	Lumen Multiplier	0-10V	Drive Current	System Watts Multiplier	Lumen Multiplier
0	4.2	350	0.50	0.56	4.2	350	0.49	0.56
1	5.1	425	0.62	0.63	5.1	425	0.60	0.63
2	5.6	475	0.68	0.70	5.6	475	0.67	0.70
3	6.2	525	0.76	0.79	6.2	525	0.73	0.79
4	6.5	550	0.80	0.80	6.5	550	0.78	0.80
5	6.8	575	0.83	0.84	6.8	575	0.81	0.80
6	7.3	625	0.90	0.91	7.3	625	0.88	0.91
7	8.4	700	1.00	1.00	8.4	700	1.00	1.00

Factory Dimming Settings		
ML Option	Low Dimming Setting	High Dimming Setting
ML2 (DL)	75mA	700mA
ML3 (DK)	175mA	70mA



LED Multi-Level Options

1050mA Drive Current

Note: For use with products when 1050mA drive current is specified. Specified drive current represents the maximum drive current that will be available with dimming option. Specifying the maximum allowed drive current for your product will provide the greatest range of dimming. Multipliers are for estimating purposes only. Check actual spec sheet data where available.

Low Dimming Settings					High Dimming Settings			
120-277V					120-277V			
Position	0-10V	Drive Current	System Watts Multiplier	Lumen Multiplier	0-10V	Drive Current	System Watts Multiplier	Lumen Multiplier
0	0.0	OFF	0.00	0.00	4.2	525	0.44	0.53
1	1.0	110	0.08	0.16	5.1	650	0.56	0.63
2	1.6	175	0.13	0.25	5.7	750	0.65	0.71
3	1.9	225	0.19	0.25	6.3	825	0.73	0.77
4	2.2	270	0.22	0.30	6.6	850	0.75	0.79
5	2.8	350	0.29	0.39	6.9	900	0.78	0.83
6	3.4	425	0.36	0.43	7.5	1000	0.87	0.91
7	3.9	500	0.42	0.51	10.0	1050	1.00	1.00

Factory Dimming Settings		
ML Option	Low Dimming Setting	High Dimming Setting
ML6 (XL)	110mA	1000mA
ML7 (XK)	270mA	1000mA

VG Series

Note: For use with products VG Series luminaires

Low Dimming Settings				High Dimming Settings		
120-277V				120-277V		
Position	0-10V	System Watts Multiplier	Lumen Multiplier	0-10V	System Watts Multiplier	Lumen Multiplier
0	0.0	0.00	0.00	4.2	0.44	0.53
1	1.0	0.08	0.16	5.1	0.56	0.63
2	1.6	0.13	0.25	5.7	0.65	0.71
3	1.9	0.19	0.25	6.3	0.73	0.77
4	2.2	0.22	0.30	6.6	0.75	0.79
5	2.8	0.29	0.39	6.9	0.78	0.83
6	3.4	0.36	0.43	7.5	0.87	0.91
7	3.9	0.42	0.51	10.0	1.00	1.00

Factory Dimming Settings		
ML Option	Low Dimming Setting	High Dimming Setting
ML	5	7
ML1	5	4
ML2	1	7
ML3	1	4
ML4	1	0
ML5	5	0

CPY Series

Note: For use with products CPY250 luminaires

Low Dimming Settings				High Dimming Settings		
120-277V				120-277V		
Position	0-10V	System Watts Multiplier	Lumen Multiplier	0-10V	System Watts Multiplier	Lumen Multiplier
0	off	0.00	0.00	4.2	0.60	0.65
1	1.0	0.14	0.15	5.1	0.73	0.78
2	1.6	0.22	0.25	5.7	0.83	0.86
3	1.9	0.26	0.30	6.3	0.91	0.93
4	2.2	0.30	0.35	6.6	0.96	0.97
5	2.8	0.39	0.44	6.9	1.00	1.00
6	3.4	0.48	0.54	7.5	1.13	1.09
7	3.9	0.55	0.61	7.5	1.13	1.09

Factory Dimming Settings		
ML Option	Low Dimming Setting	High Dimming Setting
ML	4	5
ML1	4	2
ML2	1	5
ML3	1	2
ML4	1	0
ML5	4	0

